

This drawing is the property of MELTRIC Corporation, Franklin (Milwaukee) Wisconsin, USA. Any unauthorized copying of this drawing by any means, ENG/RD/06 REV: 20 ISSUED DATE: 1/15/11 or disclosure of its contents to any person not authorized by MELTRIC Corporation or its agents to receive it, is strictly prohibited.

G F E D C B A

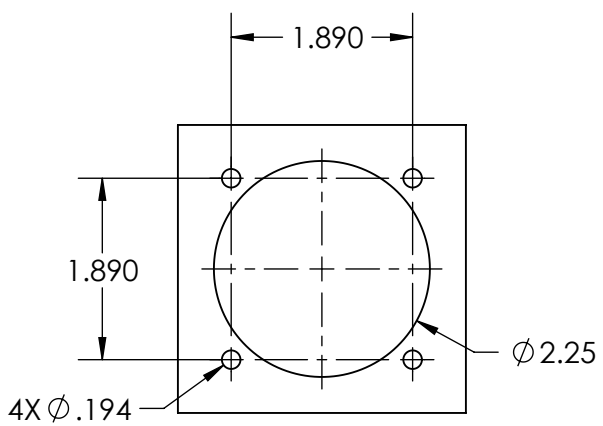

ENTRY HOLE PATTERN  
(REQUIRES ADAPTER PLATE  
PT# 45-3A540 )

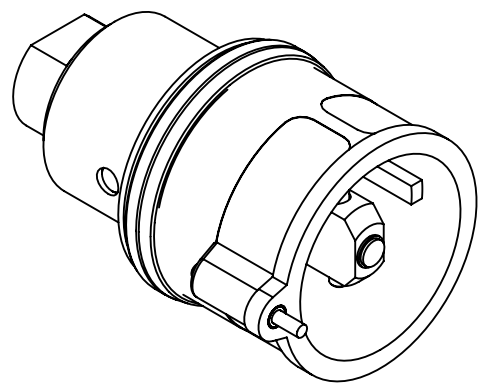
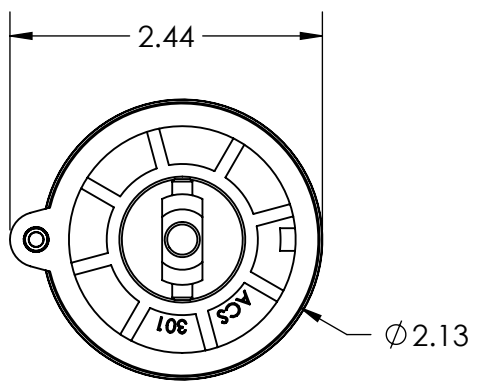
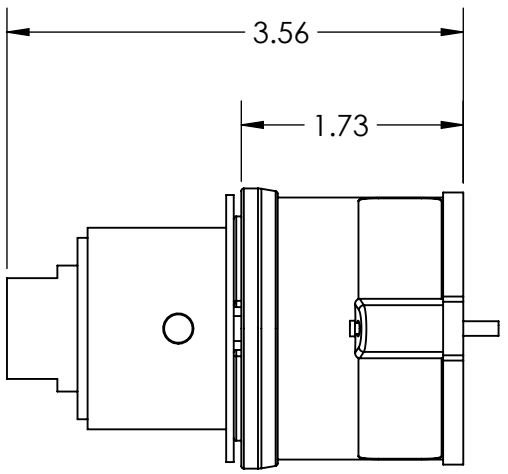
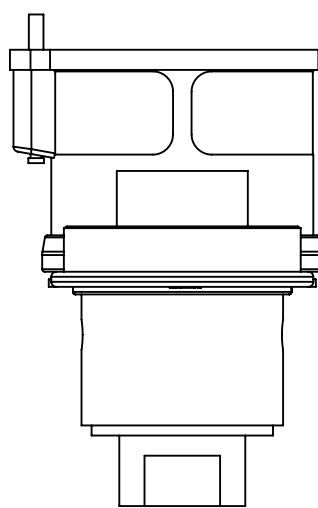

TOLERANCES UNLESS OTHERWISE SPECIFIED				DRAWING TITLE:	
MACHINED SURFACES $\sqrt{125}$ MAX	<b>ENGLISH</b> <b>0.X ±0.05</b> <b>0.XX ±0.01</b> <b>0.XXX ±0.005</b>			DATE:	SCALE
GROUND SURFACES $\sqrt{32}$ MAX			NTS	BLACK POLY CASING	
ANGLE TOLERANCE ±1° REMOVE BURRS & SHARP EDGES TO .015 MAX.		SHEET:	PART NUMBER		REVISION
DIMENSIONS SHOWN IN OVALS ARE INSPECTION DIMENSIONS.	1 OF 1	45-3800x-P80			